

JIS STANDARD CONNECTIONS

M23811

JIS BSP FEMALE 60° CONE SEAT
(TOYOTA) - JIS B 8363
(CRIMPED-BACK NUT)

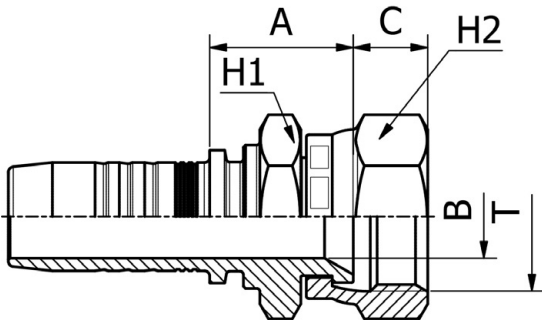

PART. REF.	HOSE BORE			Thread	DIMENSIONS mm							
	DN	Dash	inch		T	B	A	C	H1	H2		
M23811-04-04	6	- 4	1/4"	1/4" - 19		4.0	18.5	8.3	19.0	19.0		
M23811-06-06	10	- 6	3/8"	3/8" - 19		7.0	23.0	10.0	22.0	22.0		
M23811-08-08	12	- 8	1/2"	1/2" - 14		9.3	22.0	11.5	27.0	27.0		
M23811-12-12	19	- 12	3/4"	3/4" - 14		15.0	26.0	13.5	32.0	32.0		
M23811-16-16	25	- 16	1"	1" - 11		19.8	30.5	14.5	38.0	38.0		

167 FITTINGS

JIS STANDARD CONNECTIONS

M20711/M20712

JIS BSP FEMALE 60° CONE
(NISSAN) - JIS B 8363

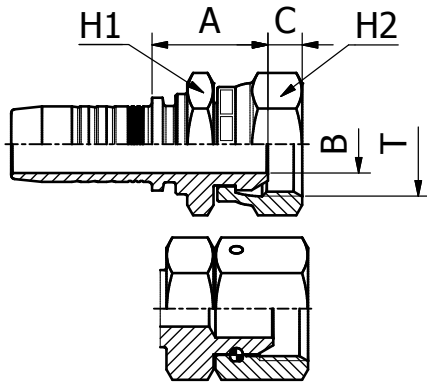

PART. REF.	HOSE BORE			Thread	DIMENSIONS mm							
	DN	Dash	inch		T	B	A	C	H1	H2		
M20711-04-04	6	- 4	1/4"	1/4" - 19		4.0	22.5	4.5	19.0	19.0		
M20711-06-06	10	- 6	3/8"	3/8" - 19		7.0	24.5	6.4	22.0	22.0		
M20711-08-08	12	- 8	1/2"	1/2" - 14		9.3	26.5	6.7	27.0	27.0		
M20711-12-12	19	- 12	3/4"	3/4" - 14		15.0	30.0	8.9	32.0	32.0		
M20712-10-08	16	- 10	5/8"	1/2" - 14		9.3	29.0	6.5	27.0	27.0		
M20712-10-12	16	- 10	5/8"	3/4" - 14		15.0	30.5	9.0	32.0	32.0		
M20712-16-16	25	- 16	1"	1" - 11		19.8	35.5	10.5	38.0	38.0		
M20712-20-20	31	- 20	1.1/4"	1.1/4" - 11		26.0	44.5	12.5	50.0	50.0		